

# DC MOLD SILENT 92X25

3.62sq.X1 (92sq.X25)



SKUD series

Silent Fan



Leads specification : UL 1007 AWG24

## DIMENSIONS : inch (mm)

● Lead wire type (Weight : 115g (0.25 lb))

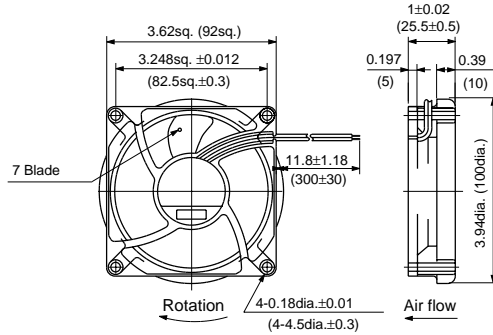

● Hole cutting size. (For reference)  
(Outlet only)

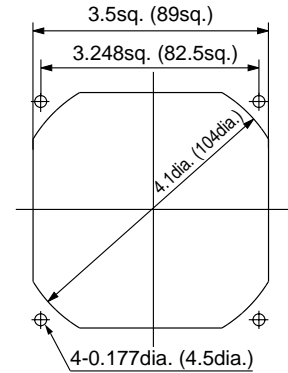

## AIR PERFORMANCE

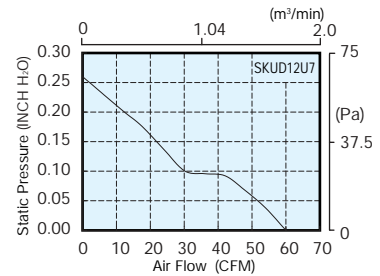
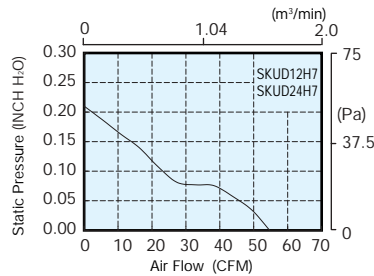
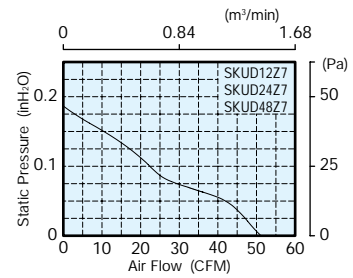
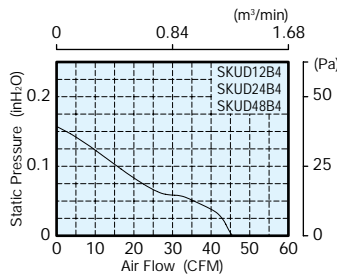
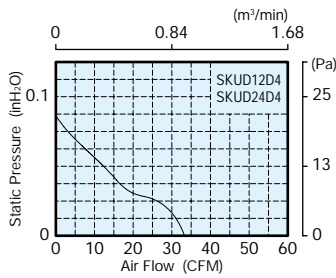

## SPECIFICATION

Max. air flow		Max. static pressure			Noise	Speed	Input	Voltage		Current	Model code	Operating temperature	
m <sup>3</sup> /min	CFM	Pa	mmH <sub>2</sub> O	inH <sub>2</sub> O				dB(A)	r/min			W	V
1.7	60	63.7	6.5	0.26	39	3500	4.2	12	7.2 - 13.8	350	SKUD12U7	-20 ~ +60	-4 ~ +140
							4.8	24	12 - 27.6	200	SKUD24U7		
1.55	54.7	54	5.5	0.21	36	3150	3.2	12	7.2 - 13.8	270	SKUD12H7		
							3.6	24	12 - 27.6	150	SKUD24H7		
1.45	51	45	4.6	0.18	34	2900	3	12	7.2 - 13.8	250	SKUD12Z7		
							3.3	24	12 - 27.6	140	SKUD24Z7		
							3.5	48	24 - 55.2	70	SKUD48Z7		
1.3	46	35	3.6	0.14	31	2600	2.9	12	7.2 - 13.8	230	SKUD12B4		
							2.4	24	12 - 27.6	130	SKUD24B4		
							2.5	48	24 - 55.2	50	SKUD48B4		
0.95	34	22	2.2	0.09	24	1950	1.4	12	8.4 - 13.8	110	SKUD12D4		
							2.4	24	14.4 - 27.6	60	SKUD24D4		